

AQTIV TOWER

PRODUCT SHEET

SYSTEM

Water	Filtered fresh, still and sparkling water	
AQTIV Technology	Through an innovative system combining a vortex mechanism, 18 micro-jets for optimal water aeration, and annular air protection around the nozzle extremity, the water flows in an accelerated movement, resulting in improved aeration and oxygenation.	
Colors	White or Black	
Product code	White: BWS-0046-WT Black: BWS-0046-BK	
Adapted for	Office	
Capacity	30 l/h	
Dimensions (mm)	H: 1531, W: 520 D: 564	
Dipensing (mm)	H: 285	
Weight (kg)	35 kg (furniture) + 4.5 kg (tap)	
Materials	Galvanized steel furniture. Non-flammable. Laminate top	

BE CONNECT

Intelligent filter head	<ul style="list-style-type: none"> Energy saving system Ensures optimal water quality and systems maintenance Controls filter and gaz capacity Checks temperature and ventilation Leak detector with automatic water flow stoppage Linked to a web application to monitor the system
Filter	<ul style="list-style-type: none"> Removal of chlorine, organic substances and "off-flavour" components Fine particles and suspended solids filtration Microplastics barrier High reduction of bacteria (99,99%) Keep good local minerals
Filter capacity	6'000L – 6 months
Dimensions (mm)	H: 350, W: 100, D: 215
GAS	
Dimensions max	H: 600, L: 200

AQTIV TOWER

PRODUCT SHEET

Needed for installation

Water inlet shut-off valve, 3/4" male connection

Electrical outlet 230 V

Under the counter

Included

Waste water canister

Elements (mm)

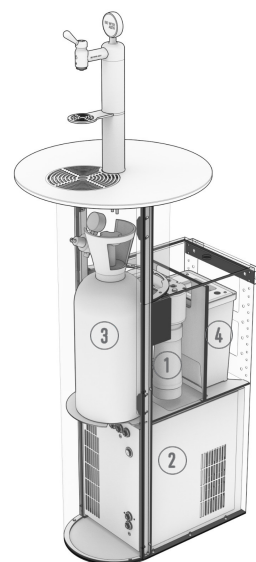
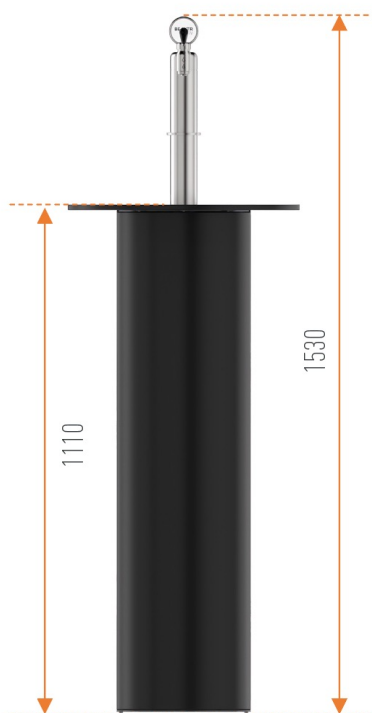

- 1 BE CONNECT + Filter
- 2 Box
- 3 Gas bottle
- 4 Water waste canister